

AC Input Solid State Relay

PCS34 AC Input



FEATURES

- High Power Solid State Relay
- SCR Output
- Load Currents from 40 to 100 Amps
- Dielectric Strength of 4,000 VAC
- Optical Isolation between Input & Output

E93379 



INPUT PARAMETERS (Ta = 30°C)

Control Voltage Range	90 ~ 280 VAC
Must Turn-On Voltage	90 VAC

Must Turn-Off Voltage	10 VAC
Max Input Current	10 mA
Max Reverse Protection Voltage	-32 VDC

OUTPUT CURRENT PARAMETERS (Ta = 30°C)

Load Current (200mA min)**	40A	50A	60A	80A	100A
Max Surge Current (10 ms, A _{pk})	700	900	900	1250	1250
Max I ² t (10 ms, A ² s)	2450	4050	4050	7800	7800
Thermal Resistance Junction to Case (R _{jc} , °C/W)	0.25	0.20	0.20	0.14	0.14

**Minimum current loading over range required to fully turn on device. Standard UL endurance ratings are 6,000 cycles.

OUTPUT VOLTAGE PARAMETERS

	240A	380A	480A	600A
Load Voltage Range (VAC)	48~280	48~440	48~530	48~660
Max Transient Voltage (V _{pk})	600	800	1200	1400
Max Turn-On Time Random Zero Crossing	1 ms 1/2 cycle + 1 ms			
Max Turn-Off Time	1/2 cycle + 1 ms			
Max Off-State Leakage Current	10 mA			
Max On-State Voltage Drop	1.7 Vrms			
Min Power Factor	0.5			
Frequency Range	47 Hz to 63 Hz			
Min Off-State (dv/dt)	500 V/us			

CHARACTERISTICS

Dielectric Strength	2500 VAC, min. Input, Output to Base 4000 VAC, min. Input to Output
Insulation Resistance	1000MΩ at 500 VDC
Max Capacitance	8pF, Input to Output
Operating Temperature	-30°C to 80°C
Storage Temperature	-30°C to 100°C
Relative Humidity	45% ~ 85%
Weight, approx.	40A ~ 80A: 95g; 100A ~ 125A: 130g

LOAD VOLTAGE / LOAD CURRENT AVAILABILITY

		Load Voltage			
		240	380	480	600
Load Current	40		X	X	
	50				
	60		X	X	
	80		X	X	
	100		X	X	X
	125		X	X	

Standard Options denoted by "X"

ORDERING INFORMATION

Example	PCS34	-A	-380A	-40	Z	L
Model:	PCS34					
Control Voltage:	A = 90~280VAC					
Load Voltage:	240A = 48~280VAC 380A = 48~440VAC 480A = 48~530VAC 600A = 48~660VAC					
Load Current:	40 = 40A 50 = 50A 60 = 60A 80 = 80A 100 = 100A 125 = 125A, not UL recognized					
Switching Type:	Z = Zero Crossing R = Random Turn-On / Instantaneous Turn-On See PRECAUTIONS #7					
Over Voltage Protection:	Nil = None Y = With Varistor (MOV) See PRECAUTIONS #8					
Status LED:	L = Indicator LED standard					
Terminal Type	Nil = Screw Terminal See PRECAUTIONS #5 for torque specification Q = Quick Connect (3/16" input, 1/4" load) Up to 50A only. Housing is fully epoxy resin filled					

PRECAUTIONS

- When choosing a Solid State Relay (SSR), note the actual load current and ambient temperature and reference the Characteristic Curves.
- SSRs require an adequate heat sinking or other effective cooling measure.
- With ambient temperature above 25°C, refer to the curve of Max Load Current vs. Ambient Temperature for load current derating.
- Apply heat-conducting silicon grease or a thermal transfer pad on the space between the SSR and heat sink and screw the SSR firmly to the heat sink to avoid damage from overheating.
- Tighten the SSR terminal screws properly. We recommend screw installation torque as follows:
 - M3 screw mounting torque range : 0.58~0.98 N*m
 - M4 screw mounting torque range : 0.98~1.37 N*m
 - M5 screw mounting torque range : 2.00~3.00 N*m
 Loose screws will damage the SSR with heat generated from connections. Also, excessive screw torque may damage the relay's internal components.
- It is recommended to use a heat sink matched to the Current Load. With any heat sink, test that the SSR base temperature does not exceed 65°C.
- When using the PCS34 relay with an inductive load, it is suggested to select Random Turn-On. (i.e. a model with "R" Switching Type)
- The PCS34 is not suitable for capacitive loads; if you must, then do not choose products with varistor protection. (i.e. a model with the "Y" Over Voltage Protection)
- Listed parameters are based on resistive loads. Do not use the relay beyond the described current, temperature, load or voltage limits as described in this datasheet.

DIMENSIONS

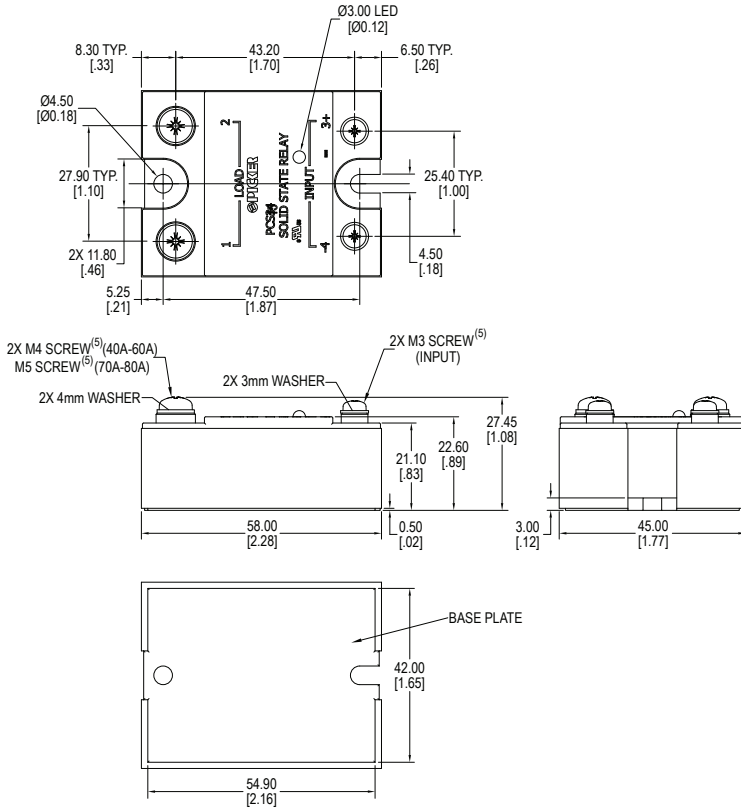

40A~80A Screw Terminals

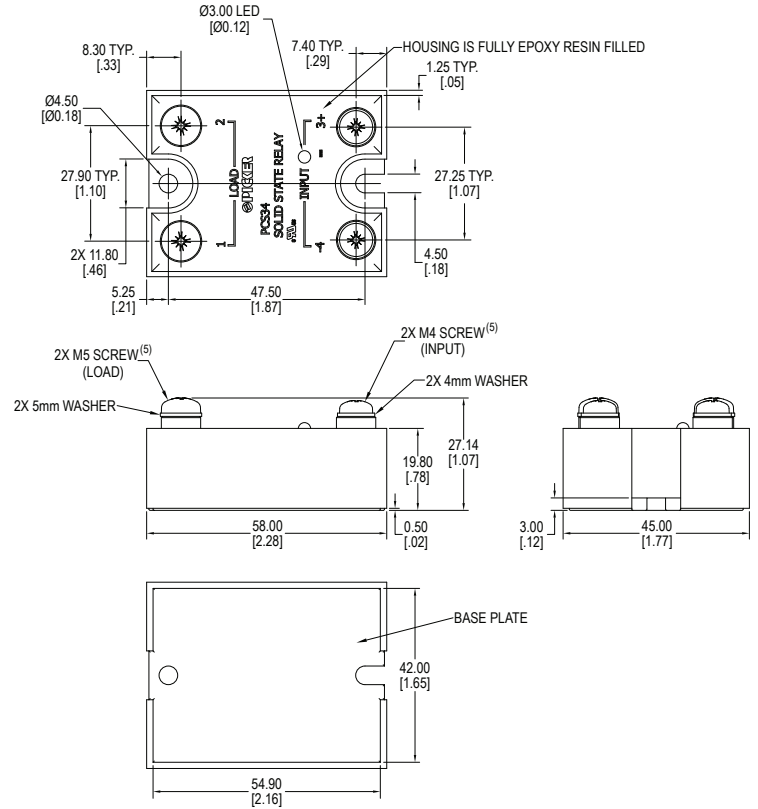

100A Screw Terminals

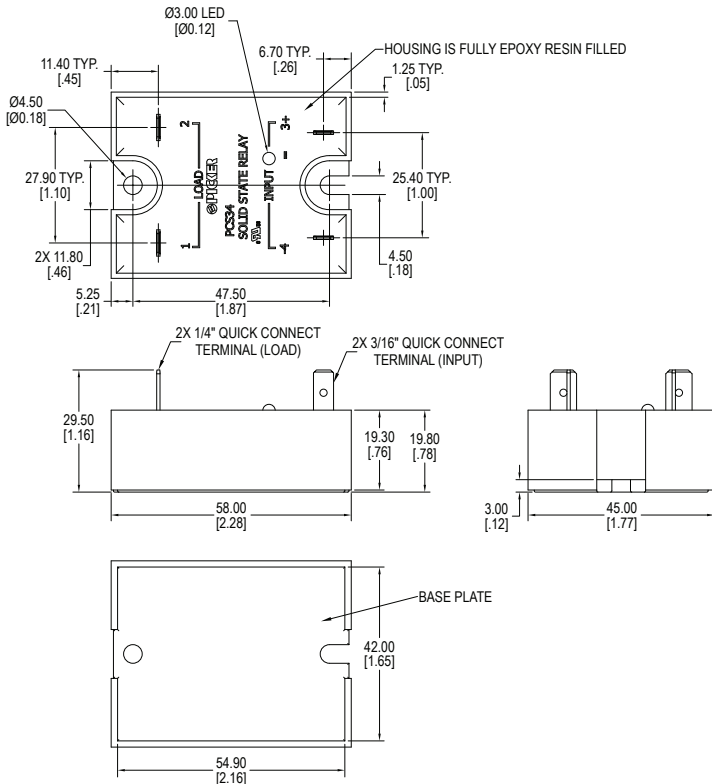

Quick Connect Terminals, up to 50 Amp only

DIMENSIONS — Continued

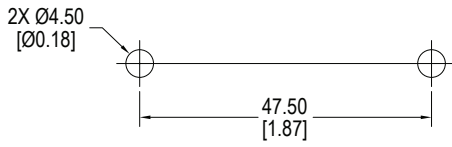

Mounting Layout

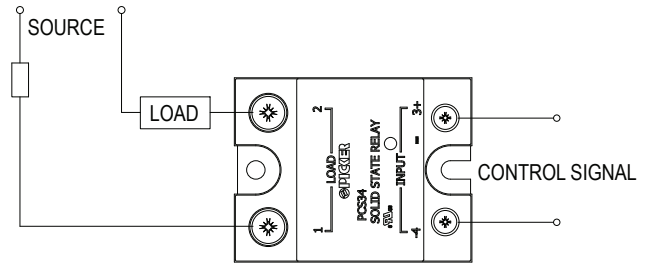

Wiring Diagram

CHARACTERISTIC CURVES

Max Load Current vs. Ambient Temperature (40A)

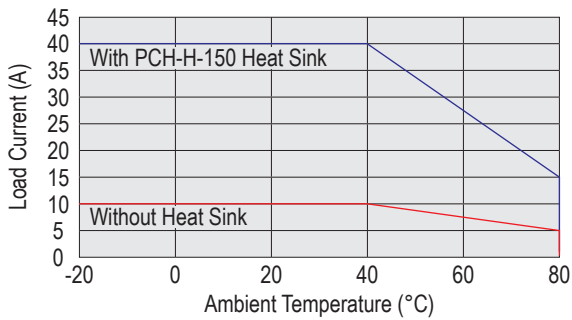

Max Load Current vs. Ambient Temperature (50A)

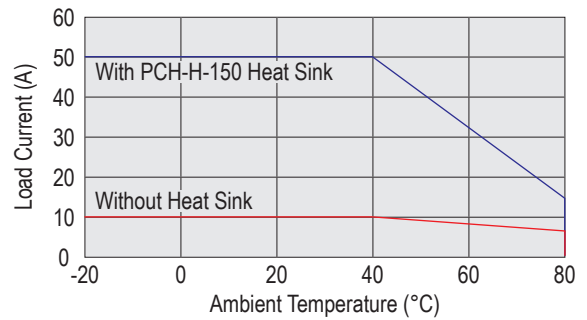

Max Load Current vs. Ambient Temperature (60A)

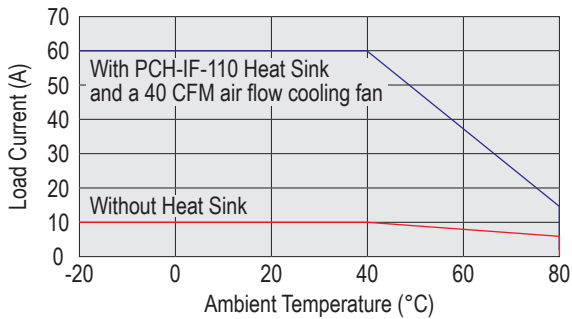

Max Load Current vs. Ambient Temperature (80A)

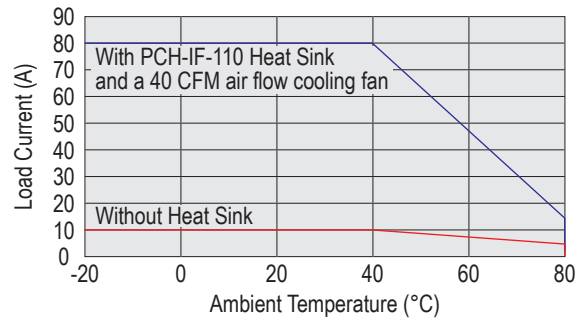

Max Load Current vs. Ambient Temperature (100A)

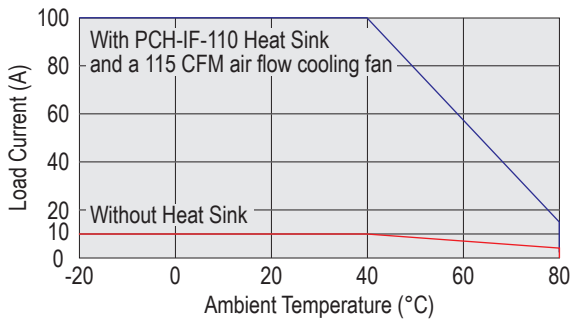

ACCESSORIES — Sold Separately

Heat Transfer Pad	HTP100
Protective Cover	SSR100
Heat Sinks	PCH-H-150 for applications 40 Amps & 50 Amps @ 25°C PCH-IF-100 for applications 60 Amps and above @ 25°C (requires an additional cooling fan)



HTP100 — Heat Transfer Pad

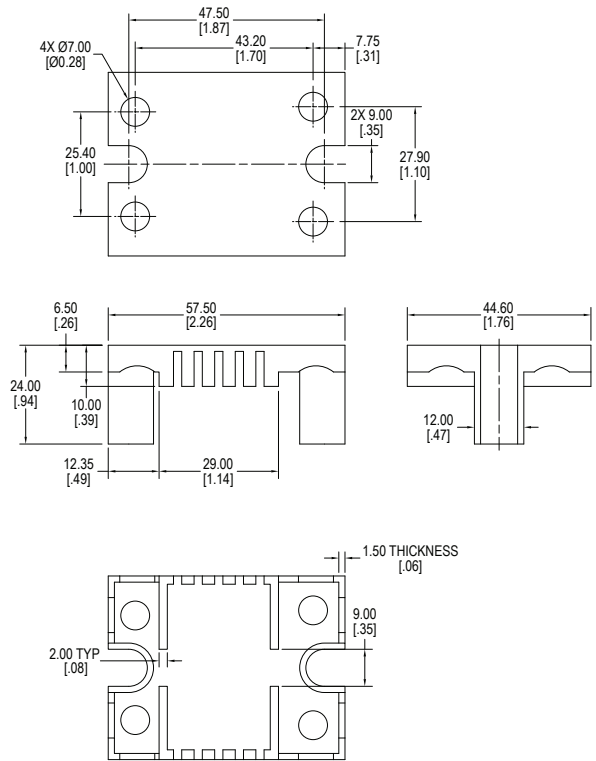

SSR100

ACCESSORIES — Sold Separately, *continued*

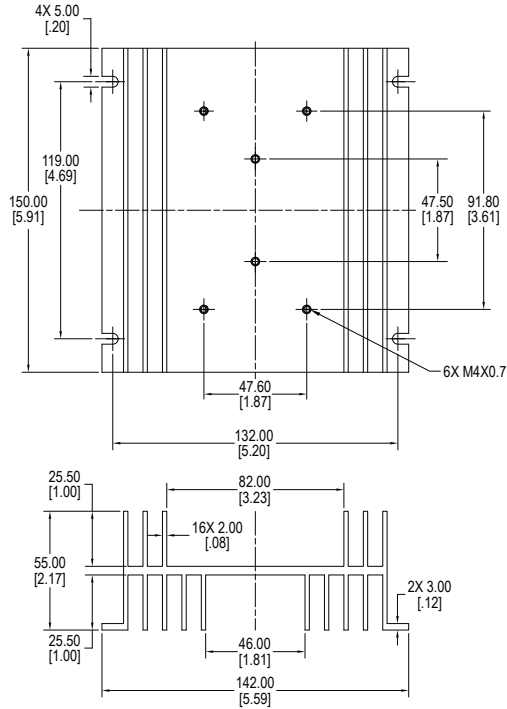

PCH-H-150 Heat Sink
40 Amp & 50 Amp

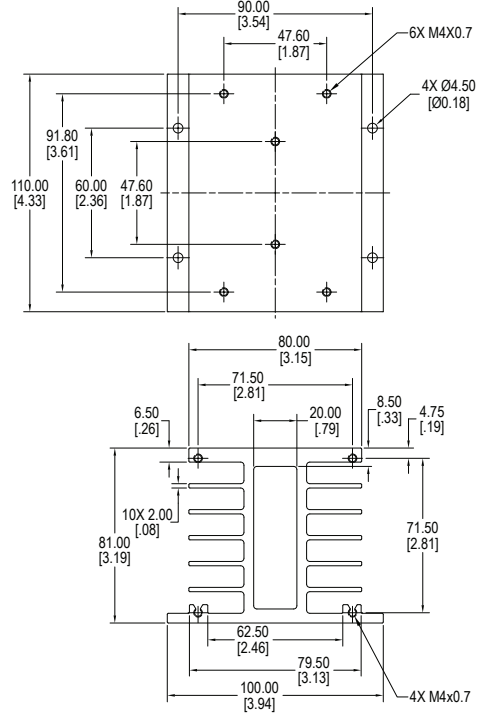

PCH-IF-110 Heat Sink
60 Amp and above, requires additional 40 CFM cooling fan